

**Spare part list 2015**

SKF 025 Motor

Pos. No.	Article no.	Description	pc.
1.1	6250511	End shield	1
1.2	SFE 105.5	Ball bearing 6206 2Z CM	1
1.3	SFE 402	Spring A6x6x32 DIN 6885	1
1.4	6250521	Armature 230V	1
1.5	SFE 105.3	Ball bearing 6204 2Z C3	1
1.6	SFE 105.6	Interspace spring ring	1
1.7	SFE 105.2	Motor housing 230V	1
1.8	6200171	Sealing gasket 4	1
1.9	6200161	Connection plate	1
1.10	SFE 105.1	Bearing plate P	1
1.11	SFE 105.10	Screw M5x168 DIN 931	3
1.12	6250531	Fan wheel	1
1.13	7010081	Screw M4x8	3
1.14	6250541	Fan cover	1

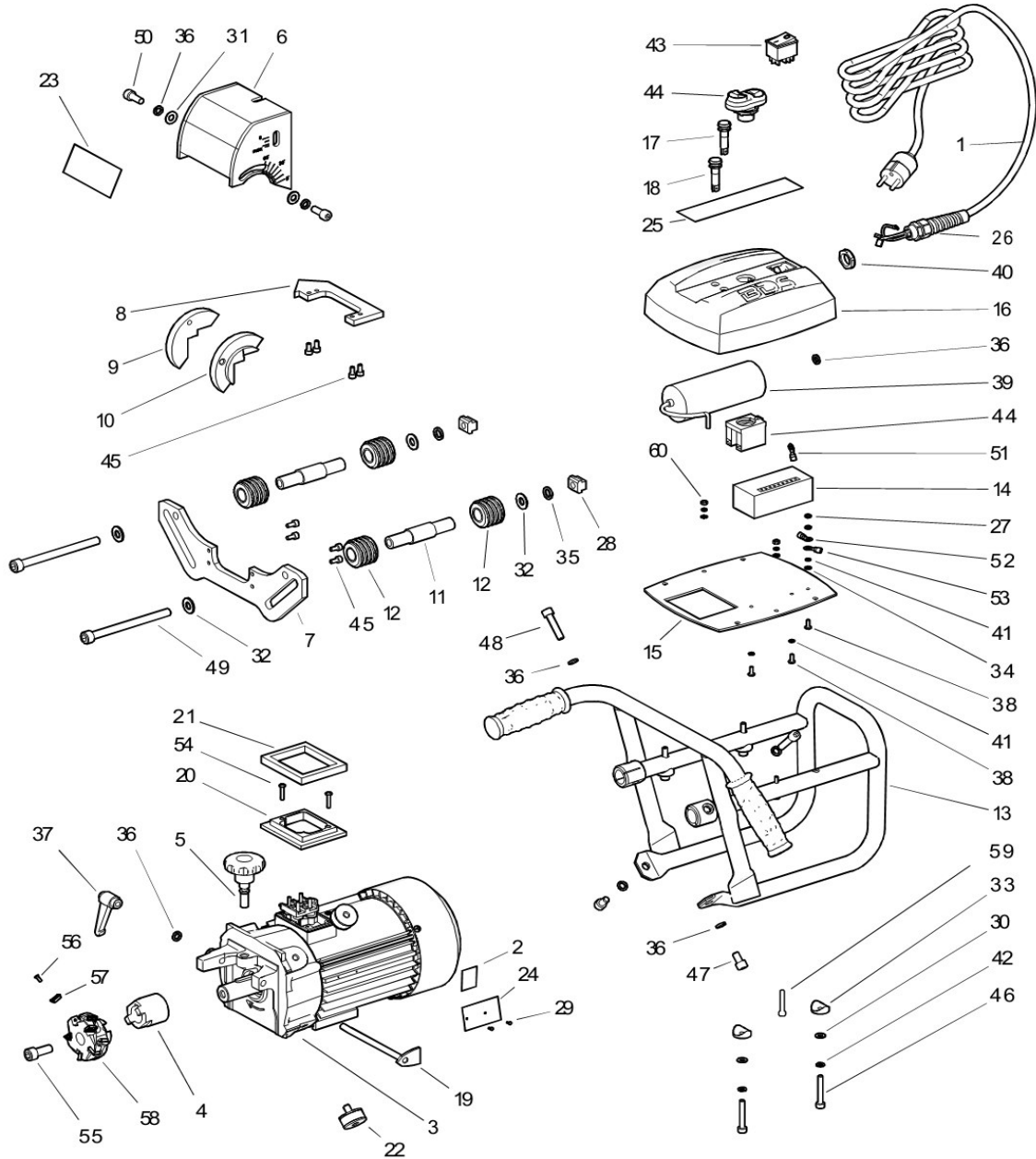

Pos. No.	Article no.	Description	pc
1.1.1	7010052	Connection cable 110V with GB-plug	1
1.2.1	7010242	Connection cable 110V with US-plug	1
1.1.2	7010042	Connection cable 230V complete with plug	1
2	6250021	Label	1
3.1	6250031	Motor 110V	1
3.2	6250041	Motor 230V	1
4	6250051	Driving collar	1
5	6250061	Locking handle	1
6	6250071	Cover for milling head	1
7.1	6250081	Vertical guidance until November 2012 - no longer available	1
7.2	6250082	Vertical guidance since November 2012	1
8	6250091	Horizontal guidance	1
9.1	6250101	Guide holder 1 until November 2012- no longer available	1
9.2	6250102	Guide holder 1 since November 2012	1
10.1	6250111	Guide holder 2 until November 2012 - no longer available	1
10.2	6250112	Guide holder 2 since November 2012	1
11	6250121	Axis	2
12	6250131	Distance roll	4
13	6250141	Grab handle complete	1
14.1	6250151	Control board 110V	1
14.2	6250161	Control board 230V	1
15	6250171	Ground plate	1
16	6250181	Housing of steering mechanism	1
17	6250191	Light red	1
18	6250201	Light yellow	1
19	6250211	Indicator	1
20	6250221	Intermediate disc	1
21	6250231	Rubber seal	1
22	6250241	Buffer	4
23	6250251	Label for milling head	1
24.1	6250261	Label 110V	1
24.2	6250271	Label 230V	1
25	6250281	Label for steering mechanism	1
26	7010031	Mains cable gland PG 11	1
27	4010271	Nut M4 DIN 934-8	2
28	6250311	T sliding block	2
29	6250321	Round-headed rivet 2x6	2
30	6012891	Washer 6,4 DIN 125A	4
31	6014151	Washer 8,4 DIN 433	3
32	6250331	Washer 10,5 DIN 433	4
33	6250341	Distance disc	4
34	6011371	Washer 4,3 DIN 6797-A	6
35	6250351	Spring washer 10,2 DIN 7980	2
36	6010571	Spring washer 8,2 DIN 7980	8
37	6250361	Clamp lever	1
38	6010521	Screw M4x10 DIN 7985	4
39.1	6250371	Capacitor 80uF/110V	1

39.2	6250381	Capacitor 30uF/230V	1
40	6014251	Cord grip round	1
41	6011301	Spring washer 4,1 DIN 7980	6
42	6010021	Spring washer 6,1 DIN 7980	4
43	7010142	Magnet switch 4 connection terminals	1
44	7010111	Actuator	1
45	6250411	Hexagon socket M5x10 DIN 912	8
46	6250421	Hexagon socket M6x40 DIN 912	4
47	6250431	Hexagon socket M8x14 DIN 912	2
48	6050241	Hexagon socket M8x35 DIN 912	2
49	6250441	Hexagon socket M10x120 DIN 912	2
50	6050091	Hexagon socket M8x20 DIN 912	2
51	6250461	Wiring set for switch on/off	1
52	6250471	Earthing cable for connection plate	1
53	6250481	Motor cable	1
54	6250491	Screw with cross slot M4x20 DIN 7985	2
55	7011721	Hexagon socket M10x25 DIN 912	1
56	7012141	Clamping screw M3,5-2+8,5 T15 for SHM 800	10
57	SHM 800	HM-High speed insert	10
58	ZFR 250	Shell-type milling cutter	1
59	6250501	Screw with cross slot M4x30 DIN 7985	2

